

## INTRODUCTION

**SBPT** is an ISO 9001: 2000 certified company, specializing in Design and Manufactures of highly flexible Diaphragm Coupling since 1994.

Advance analysis and manufacturing process have produced increased rating without reducing safety factors. The use of Torsional Vibration Analysis package has allowed for a more precise calculation on the drive system stresses.

Flexible couplings are a vital part of mechanical power transmission system. Unfortunately some consider it a hardware only. It hardly costs 1% of the total system cost. And yet it can cause severe financial losses when improperly designed / selected or operated.

SBPT has grown to be the largest Indian manufacturer of Flexible Diaphragm couplings.

## SBPT DIAPHRAGM COUPLING

The SBPT highly flexible Diaphragm Coupling is a fabric-reinforced rubber coupling with multi-directional flexibility. The use of synthetic fiber guarantees high strength. The coupling is used in applications where two approximately co-axially rotating machines have to be flexibly connected such as diesel engine and electric motor-driven equipment including marine propulsion systems, two-bearing generators, compressors, pumps, fans, crushers, ball and rolling mills.

## FEATURES

- Sizes available to transmit up to 300 kNm of torque.
- Allows 3-25 degree torsional deflection.
- Rupture torque 7-9 times of nominal torque.
- Progressive dynamic torsional stiffness ... increases with increasing torque.
- Dampens torsional vibrations.
- Provides precise systems tuning... several torsional stiffnesses are available for each coupling size.
- Accommodates misalignment.
- Absorbs shocks and attenuates noise.
- Rubber-in-shear design serves as a mechanical fuse to protect equipment from excessive torque overload.
- Requires no lubrication / maintenance.
- Available blind assembly and in single diaphragm designs.
- Custom built designs available.

### PARTS

- 1) Hub
- 2) Flanged Casing
- 3) Intermediate Ring
- 4) Inner Clamping Ring
- 5) Rubber Diaphragms
- 6) Outer Clamping Ring
- 7) Inner Clamping Screw
- 8) Inner Screw
- 9) Outer Clamping Screw
- 10) Adapter Ring

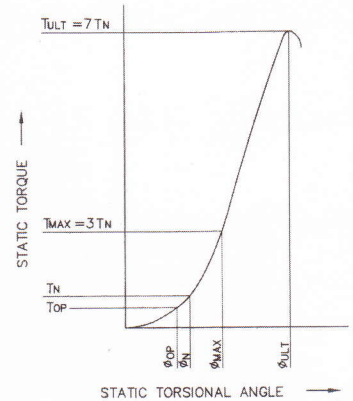
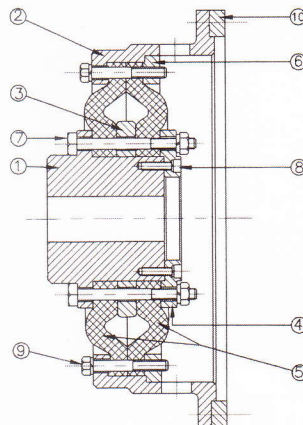

## APPLICATION

Land or sea, stationary or mobile, you will find SBPT Diaphragm Coupling powering a wide range of application such as Marine, Road Construction, Mining, Compressor, Locomotives and other equipments. No matter what application is, there is a reliable, SBPT Diaphragm Coupling ready to operate.

## TECHNICAL DATA

SIZE SB / EZ	Permissible Values			Static Torsional angle at Tnom In degree.	Permissible Speed RPM (N)		Permissible Displacement		Deflection Stiffness Kp/mm.		Dynamic Torsional Stiffness (X1000) in kpcm / rad			
	Nominal Torque kNm Tn	Max. Torque in KNm Tmax	Vib. Torque in KNm Tv		CS Casing	CI Casing	Axial mm. K <sub>a</sub>	Radial mm. K <sub>r</sub>	Axial C <sub>a</sub>	Radial C <sub>r</sub>	C <sub>tdyn</sub> at 25%	C <sub>tdyn</sub> at 50%	C <sub>tdyn</sub> at 75%	C <sub>tdyn</sub> at 100%
45S	0.55	1.65	0.22	23.0	4600	3000	3.5	1.0	18	24	15	27	40.5	59
50S	0.60	1.80	0.24	21.0	4000	2600	3.5	1.0	18	24	20	28	44	61
51S	0.65	1.95	0.26	20.0	4000	2600	4.0	1.25	18	25	21	30	48	66
55S	0.75	2.25	0.30	24.0	4000	2600	4.0	1.25	18	25	18	36	60	90
61S	1.0	3	0.40	13.0	3550	2300	4.5	1.5	34	52	48	85	127	188
65S	1.4	4.2	0.56	16.5	3500	2275	4.5	1.5	34	52	57	101	147	216
71S	1.7	5.1	0.68	15.0	3050	2000	5.0	1.7	64	96	91	135	190	280
80S	2.3	6.9	0.92	18.0	3050	2000	5.0	1.7	64	96	105	156	254	346
86S	3.0	9.0	1.20	12.5	2600	1700	6.0	2.0	90	96	163	248	349	537
95S	4.2	12.6	1.68	15.0	2600	1700	6.0	2.0	90	96	180	301	445	624
102S	5.0	15.0	2.00	11.0	2250	1475	7.0	2.3	150	241	322	450	649	870
115S	7.0	21.3	2.80	15.0	2250	1475	7.0	2.3	150	241	334	608	880	1158
121S	8.87	26.6	3.55	12.0	1950	1275	7.5	2.5	140	180	552	777	1106	1398
135S	12.0	36.0	4.80	14.5	1950	1275	7.5	2.5	140	180	602	914	1366	1830
141S	14.8	44.4	5.92	12.0	1675	1100	8.0	3.0	215	275	770	1376	2180	2996
165S	20.2	60.6	8.08	14.5	1675	1100	8.0	3.0	215	275	884	1978	3096	4198
171S	25.0	75.0	10.00	14.5	1500	950	9.2	3.6	305	315	1144	1726	2531	3518
195S	34.5	103.5	13.80	18.0	1500	950	9.2	3.6	305	315	1214	2178	3648	5086
201S	44.5	133.5	17.80	14.5	1200	800	10.0	4.2	270	365	2118	3484	5544	8122
230S	54.2	162.6	21.68	16.0	1200	800	10.0	4.2	270	365	2268	4278	6763	10210
235S	69.0	207.0	27.60	18.5	1200	800	10.0	4.2	270	365	2802	5626	9061	13870
275S	105.0	315.0	42.00	18.0	1050	700	11.0	4.6	335	440	3856	7160	11651	18183
310S	177.5	532.5	71.0	13.5	850	550	13.0	5.5	1010	1460	9660	16574	25110	35678
320S	236.0	708.0	94.4	15.0	850	550	13.0	5.5	1010	1460	10744	21887	34840	47400
360S	301.0	903.0	120.40	18.0	850	550	13.0	5.5	1010	13970	14040	26330	42510	65930

### SELECTION

1. Select the Service Factor S based on application from the Table.
2. Calculate Torque (T) in kNm  
 $T = KW \times 9550 \times S / 1000 \text{ RPM}$   
 or  $T = HP \times 716.2 \times 9.86 \times S / 1000 \text{ RPM}$
3. Select coupling size having Tnom > T
4. Check for maximum bore limit. If the maximum bore is exceeded, move to higher coupling size.
5. Check the RPM and select casing material.

### Guideline for Typical Service Factor 'S'

LOAD CLASSIFICATION	SERVICE FACTOR S
Continuous service and low running load variation	1.20
Torque loading varies during operation	1.50
For medium shock loading or light reversing drive	1.75
For heavy shock loading / reversing drive	2.00

**WE ALSO INDEPENDENTLY DEVELOPED REPLACEMENT VULKAN EZ/EZS/EZR RUBBER ELEMENTS & FLENDER-ELPEX GUARANTEED TO PROVIDE EXCELLENT PERFORMANCE AT HIGHLY ATTRACTIVE PRICES.**



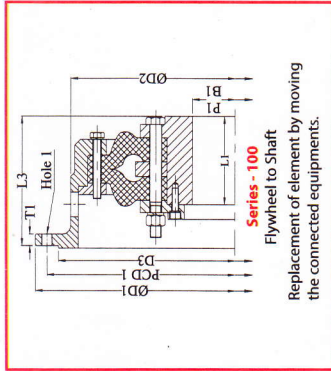

**Series - 100**  
Flywheel to Shaft  
Replacement of element by moving  
the connected equipments.

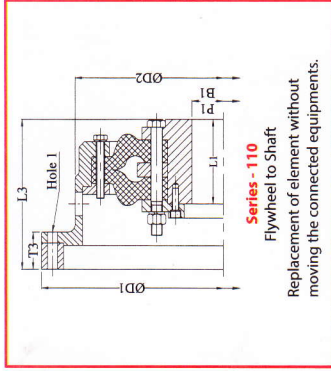

**Series - 110**  
Flywheel to Shaft  
Replacement of element without  
moving the connected equipments.

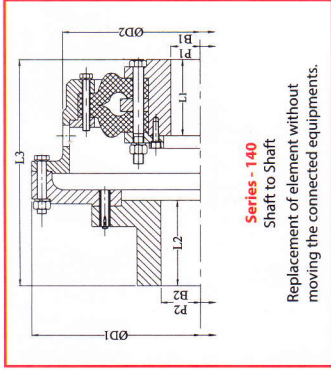

**Series - 140**  
Shaft to Shaft  
Replacement of element without  
moving the connected equipments.

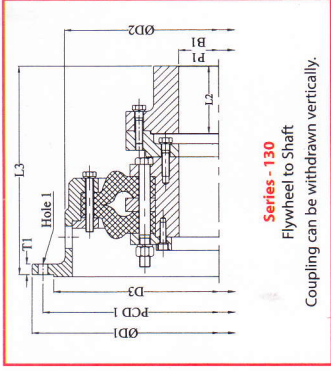

**Series - 130**  
Flywheel to Shaft  
Coupling can be withdrawn vertically.

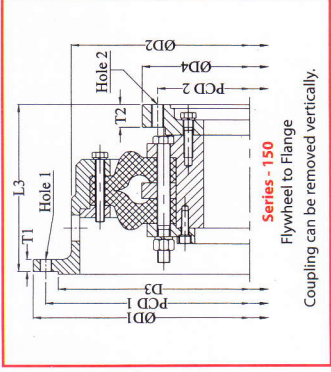

**Series - 150**  
Flywheel to Flange  
Coupling can be removed vertically.

## DIMENSIONAL TABLE

Size SB/EZ	D1 in mm.	D2 in mm.	D3 in mm.	D4 in mm.	Min Bore in mm. B1/B2	Max Bore in mm. P1/P2	L1 in mm.	L2 in mm.	PCD1 in mm.	PCD2 in mm.	Hole N1 nos. -d1 dia in mm.	Hole N2 nos. -d2 dia in mm.	T1	T2	T3	L3 in mm. for the Series				
													in mm.	in mm.	in mm. for series 110	100	110	140	130	150
45 S	252	210	218	113	20/20	48/60	62	62	235	99	12-10	6-8.5	8	18	28	83	110	176	161	102
50 S	290	238	246	135	25/25	55/70	69	71	268	118	12-11	6-11	10	21	28	92	119	196	183	115
51 S	290	238	246	135	25/25	55/70	69	71	268	118	12-11	6-11	10	21	28	92	119	196	183	115
55 S	290	238	246	135	25/25	55/70	69	71	268	118	12-11	6-11	10	21	28	92	119	196	183	115
61 S	330	270	278	156	30/30	65/80	80	90	304	134	12-15	6-13	12	26	36	106	143	243	220	134
65 S	330	270	278	156	30/30	65/80	80	90	304	134	12-15	6-13	12	26	36	106	143	243	220	134
71 S	380	317	328	205	40/40	75/110	103	111	354	170	12-15	6-15	14	27	30	132	162	285	269	162
80 S	380	317	328	205	40/40	75/115	103	111	354	170	12-15	6-15	14	27	30	132	162	285	269	162
86 S	445	375	392	230	50/50	100/130	126	130	420	198	12-15	6-20	14	34	32	162	193	333	324	199
95 S	445	375	392	230	50/50	100/140	126	130	420	198	12-15	6-20	14	34	32	162	193	333	324	199
102 S	514	438	458	271	60/60	115/150	143	150	486	230	16-17	6-20	16	38	39	185	223	387	371	226
115 S	514	438	458	271	60/60	115/160	143	150	486	230	16-17	6-20	16	38	39	185	223	387	371	226
121 S	593	509	529	298	70/70	130/170	168	175	561	264	16-17	6-22	18	44	42	216	261	455	433	263
135 S	593	509	529	298	70/70	135/180	168	175	561	264	16-17	6-22	18	44	42	216	261	455	433	263
141 S	690	584	610	358	80/80	150/205	199	200	650	322	16-22	8-22	25	54	91	268	334	528	518	324
165 S	690	584	610	358	80/80	155/215	199	200	650	322	16-22	8-22	25	54	91	268	334	528	518	324
171 S	810	696	726	420	95/95	185/245	222	230	767	378	16-26	8-26	28	60	105	308	385	609	596	372
195 S	810	696	726	420	95/95	190/250	222	230	767	378	16-26	8-26	28	60	105	308	385	609	596	372
201 S	960	822	858	540	115/115	230/290	258	275	908	480	16-32	8-33	32	56	132	360	460	730	686	416
230 S	960	822	858	540	115/115	230/290	258	275	908	480	16-32	8-33	32	56	132	360	460	730	686	416
235 S	960	822	858	540	115/115	230/290	258	275	908	480	16-32	8-33	32	56	132	360	460	730	686	416
275 S	1110	953	992	630	135/135	280/330	302	340	1051	565	16-35	12-33	35	74	163	440	569	904	845	511
310 S	1388	1194	1244	850	225/225	330/380	400	475	1315	750	24-38	12-48	40	85	200	520	680	1147	1002	535
320 S	1388	1194	1244	850	225/225	330/390	400	475	1315	750	24-38	12-48	40	85	200	520	680	1147	1002	535
360 S	1388	1194	1244	850	225/225	330/400	400	475	1315	750	24-38	12-48	40	85	200	520	680	1147	1002	535

**NOTE :** 1) Weight and M.I depend on shaft diameter and shall be indicated in the GA Drg.

2) The above design is without Torsional Limit Device. Contact SBPT for Torsional Limit Device.